

Calibration Algorithm Based on NSA(C)9260X

AN-12-0024

Author: Feifei Sun



Calibration Algorithm Based on NSA(C)9260X

ABSTRACT

This article mainly introduces the internal algorithm process of NSA(C)9260X, from the collection of raw data to the final output of voltage data.

INDEX

1. PIN CONFIGURATION AND FUNCTIONS	2
2. DATA NORMALIZATION	2
3. TEMPERATURE CHANNEL TADC CALIBRATION	3
3.1. INTERNAL TEMPERATURE SENSOR MODE	3
3.2. EXTERNAL TEMPERATURE SENSOR MODE	3
4. PADC CALIBRATION	4
4.1. SENSOR CALIBRATION	5
5. RANGE ADJUSTMENT	6
6. DAC CALIBRATION	7
7. SENSOR CALIBRATION PROCESS OF DIGITAL OUTPUT	7
8. CALIBRATION DLL DESCRIPTION	8
8.1. INPUT PARAMETERS:	8
8.2. OUTPUT PARAMETERS:	9
9. REVISION HISTORY	10

Calibration Algorithm Based on NSA(C)9260X

1. Pin Configuration and Functions

NSA(C)9260X signal chain is illustrated in Figure 1.1. Sensor output signal will be amplified through analog front end and will be quantized by PADC into a 24-bit digital output. Internal temperature sensor or external temperature sensor output will be amplified through auxiliary temperature measurement channel and quantized by TADC into a 24-bit temperature digital output. These two digital outputs will be calibrated by a built-in MCU and output to DAC to generate final analog voltage or current outputs. Calibration algorithm embedded in MCU, and corresponding calibration coefficients are stored in one 64-byte EEPROM. Calibration algorithm can be divided into ADC calibration (ADC CAL), sensor calibration (SENSOR_CAL), range ratio adjustment, and DAC calibration (DAC CAL). ADC calibration is to calibrate zero point and sensitivity of PADC output and TADC output. Sensor calibration is to calibrate sensor offset, sensitivity, non-linearity, and temperature drift of offset and sensitivity. Range ratio adjustment supports user to modify the product's range after module calibration is completed. DAC calibration is to calibrate zero point and sensitivity deviation of the analog output.

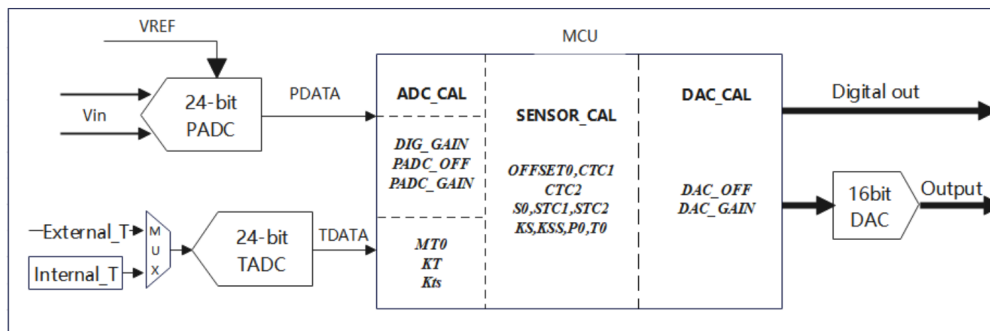

Figure1.1 NSA(C)9260X SIGNAL CHAIN

2. Data Normalization

In order to unify the data format and unit during the calibration, the output data of PADC and TADC, input data of DAC must be normalized. The normalized data is the ratio between the physical quantity and the full scale. For example, the normalized data of PADC data $PDATA_{RAW}$ is showed below:

$$PDATA_{RAW} = \frac{Vin * GAIN_P}{VREF} = \frac{PDATA[23:0]}{2^{23}}$$

Calibration Algorithm Based on NSA(C)9260X

Symbol	Description
V _{in}	Voltage signal of input (V)
GAIN_P	Amplify factor of PGA
VREF	Reference voltage of ADC
ADC [23:0]	Output code of ADC, 24 bit complement code, PDATA [23] is sign bit, range is -2 ²³ to 2 ²³ -1

The normalized data of DAC input is showed below:

$$DAC_DATA = \frac{DACOUT}{DACFS} = \frac{DAC_DATA[15:0]}{2^{16}}$$

Symbol	Description
DACOUT	Analog voltage or current output
DACFS	Full scale of DAC output
DAC_DATA [15:0]	Input code of DAC, unsigned, range is 0 to 2 ¹⁶

3. Temperature Channel TADC Calibration

NSA(C)9260X support two temperature measurement modes, internal temperature sensor mode and external temperature sensor mode.

3.1. Internal temperature sensor mode

NSA(C)9260X internal temperature sensor is calibrated before sent out, and the calibration coefficient (MT0, KT) is saved in the register. If the system use internal temperature sensor, please don't modify the MT0 and KT register data. The temperature data can be read from TDATA register, the data format is

$$T_{int} = TDATA_{CAL} + 25^{\circ}C$$

The 25 °C offset can support the output of temperature up to 153 °C

3.2. External temperature sensor mode

The calibrated data can be read from register TDATA when using external temperature sensor. The output of TADC is TDATARAW, and the calibration formula shows below:

Calibration Algorithm Based on NSA(C)9260X

$$TDATA_{CAL} = T0 + (TDATA_{RAW} - MT0) * KT * [1 + KTS * (TDATA_{RAW} - MT0) * KT] * 128$$

The calibrated data format of external temperature sensor is recommended to set as below:

$$T_{ext} = TDATA_{CAL} + 25^{\circ}\text{C}$$

T_{ext} is calibrated temperature data.

The parameter description of the formula is showed below :

Symbol	Description	Range	Default value	Data format
T0	Reference temperature, default is 0	(-128,128)	0	8-bit sign
$TDATA_{CAL}$	Calibrated temperature, saved at TDATA	(-128,128)	---	24-bit sign
$TDATA_{RAW}$	Raw data of TADC, saved at register TDATA.	(-1,1)	---	24-bit sign
MT0	Offset calibration coefficient of temperature sensor	(-1,1)	0	16-bit sign
KT	Full scale calibration coefficient of temperature sensor	(-8,8)	0	16-bit sign
KTS	Second-order nonlinearity coefficient of temperature sensor	(-1,1)	0	8-bit sign

4.PADC Calibration

PADC calibration is to calibrate offset and full scale of main signal channel (P channel).

$$PDATA_{CAL1} = (PDATA_{RAW} - PADC_OFF) * (1 + PADC_GAIN) * DIG_GAIN$$

Symbol	Description	Range	Default value	Data format
$PDATA_{CAL1}$	Intermediate variable, output of PADC calibration	(-2,2)	---	---
PADC_OFF	Offset calibration coefficient of P channel	(-1,1)	0	24-bit sign
PADC_GAIN	Full scale calibration coefficient of P channel	(-0.5,0.5)	0	16-bit sign
DIG_GAIN	Digital gain of P channel	1,2,4,8	1	2-bit

Calibration Algorithm Based on NSA(C)9260X

4.1. Sensor calibration

NSA(C)9260X can regulate offset and full scale of sensor. The second-order temperature coefficient of offset and full scale can be calibrated. Meanwhile, third-order nonlinearity coefficient of sensor can be calibrated.

$$\text{OFFSET} = \text{OFFSET0} + \text{CTC1} * (\text{TDATA}_{\text{CAL}} - \text{T0}) + \text{CTC2} * (\text{TDATA}_{\text{CAL}} - \text{T0})^2$$

$$S = S0 * (1 + \text{STC1} * (\text{TDATA}_{\text{CAL}} - \text{T0}) + \text{STC2} * (\text{TDATA}_{\text{CAL}} - \text{T0})^2)$$

$$P_{\text{NL}} = (\text{PDATA}_{\text{CAL1}} - \text{OFFSET}) * S$$

$$\text{PDATA}_{\text{CAL2}} = P_{\text{NL}} + \text{KS} * P_{\text{NL}}^2 + \text{KSS} * P_{\text{NL}}^3 + P0$$

Symbol	Description	Range	Default value	Data format
PDATA _{CAL2}	Intermediate variable, the data after linearity calibration	(-2,2)	---	---
OFFSET0	Offset calibration coefficient of sensor	(-1,1)	0	16-bit sign
CTC1	First-order temperature coefficient of sensor offset	(-0.00781,0.00781)	0	16-bit sign
CTC2	Second-order temperature coefficient of sensor offset	(-6.1e-5,6.1e-5)	0	16-bit sign
S0	Sensor sensitivity temperature coefficient	(0,2)	0	16-bit unsigned
STC1	First-order temperature coefficient of sensor sensitivity	(-0.00781,0.00781)	0	16-bit sign
STC2	Second -order temperature coefficient of sensor sensitivity	(-6.1e-5,6.1e-5)	0	16-bit sign
KS	Sensor second-order nonlinearity coefficient	(-1,1)	0	16-bit sign
KSS	Sensor third-order nonlinearity coefficient	(-0.5,0.5)	0	16-bit sign
P0	Nonlinearity calibration reference pressure value	(-1,1)	0	8-bit sign

For temperature sensor application such as RTD temperature measurement, it only needs the main channel, so the temperature calibration coefficient CTC1, CTC2, STC1, STC2 can be set to 0, so the calibration formula can be simplified as below:

$$P_{\text{NL}} = (\text{PDATA}_{\text{CAL1}} - \text{OFFSET0}) * S0$$

$$\text{PDATA}_{\text{CAL2}} = P_{\text{NL}} + \text{KS} * P_{\text{NL}}^2 + \text{KSS} * P_{\text{NL}}^3 + P0$$

Calibration Algorithm Based on NSA(C)9260X

5. Range Adjustment

The data after sensor calibration will be calculated using below formula, the result PDATA_{CAL} will be saved into register PADTA. The range adjustment coefficient SCALE_{OFF} and SCALE_S are used for range override easily. For the product which range will adjustment in the future, recommend to set SCALE_{OFF} to 0, SCALE_S to 1, and use the maximum range to calibrate during initial calibration. Later, if the product need range adjustment, only need to adjust these two coefficients.

$$PDATA_{CAL} = (PDATA_{CAL2} - SCALE_{OFF}) * SCALE_S$$

Symbol	Description	Range	Default value	Data format
PDATA _{CAL}	Digital output after calibration	(-1,1)	---	24-bit sign
SCALE _{OFF}	Offset calibration	(-1,1)	0	24-bit sign
SCALE _S	Full scale calibration	(0,256)	0	24-bit unsigned

Take a 4~20mA output pressure transmitter as an example, the initial calibration pressure range is LP0~HP0, and DAC is calibrated, then the relationship between PDATA and output current is ILOOP=24mA*PDATA, LP0 corresponding PDATA digital output is 1/6, HP0 corresponding PDATA digital output is 5/6. Now the range will be adjusted to LP1~HP1, this means to adjust the coefficients SCALE_{OFF} and SCALE_S, then the pressure point LP1 and HP1 corresponding PDATA digital output is 1/6 and 5/6. Suppose the range adjustment coefficient is SCALE_{OFF}_{old} and SCALE_S_{old} at present. Then the new range adjustment coefficients can be calculated using the formula below:

$$SCALE_{OFF}_{new} = \frac{5LP1 - HP1 - 5LP0 + HP0}{6SCALE_{S}_{old} * (HP0 - LP0)} + SCALE_{OFF}_{old}$$

$$SCALE_{S}_{new} = \frac{HP0 - LP0}{HP1 - LP1} SCALE_{S}_{old}$$

For example, if the initial range of a 4~20mA pressure transmitter is 0~100kPa, SCALE_{OFF} is 0, and SCALE_S is 1. In order to adjust range to 0~50kPa, only need to adjust SCALE_{OFF} to 1/12 and SCALE_S to 2.

Calibration Algorithm Based on NSA(C)9260X

6.DAC Calibration

NSA(C)9260X use DAC_OFF, DAC_GAIN to calibrate the offset and full scale of analog voltage or current output. The formula is showed below, DAC_DATA (positive value) is 16-bit input of DAC. After DAC calibration, the error of analog output is reduced, so the analog output can be calculated correctly using PDATA_{CAL} directly. Owe to the low temperature drift of internal reference voltage, only need to calibrate DAC once at room temperature. The temperature calibration coefficients of the sensor will be calibrated at the digital output.

$$DAC_DATA = (PDATA_{CAL} - DAC_OFF) * (1 + DAC_GAIN)$$

Symbol	Description	Range	Default value	Data format
DAC_DATA	Calibrated input of DAC	(0,1)	0	16-bit unsigned
DAC_OFF	Offset calibration coefficient of DAC	(-1,1)	0	16-bit sign
DAC_GAIN	Full scale calibration coefficient of DAC	(-0.5,0.5)	0	16-bit sign

7.Sensor Calibration Process of Digital Output

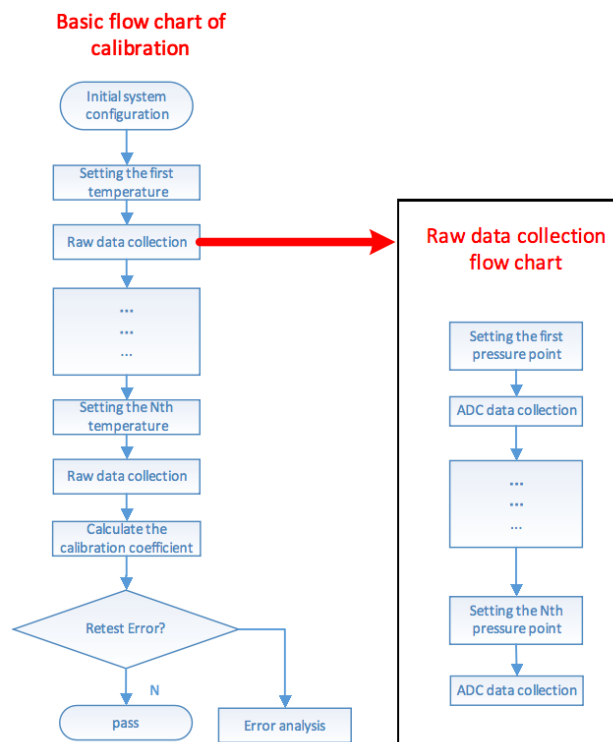

Figure 7.1 Sensor calibration process

Calibration Algorithm Based on NSA(C)9260X

Table 7.1: Relationship between calibration coefficients and the least data collection point

	T1				T2				T3				
OFFSET0、S0	P1	P2	--	--	--	--	--	--	--	--	--	--	--
OFFSET0、S0、KS	P1	P2	P3	--	--	--	--	--	--	--	--	--	--
OFFSET0、S0、KS、KSS	P1	P2	P3	P4	--	--	--	--	--	--	--	--	--
OFFSET0、S0、CTC1、STC1	P1	P2	--	--	P1	P2	--	--	--	--	--	--	--
OFFSET0、S0、CTC1、STC1、KS	P1	P2	P3	--	P1	P2	--	--	--	--	--	--	--
OFFSET0、S0、CTC1、STC1、KS、KSS	P1	P2	P3	P4	P1	P2	--	--	--	--	--	--	--
OFFSET0、S0、CTC1、CTC2、STC1、STC2	P1	P2	--	--	P1	P2	--	--	P1	P2	--	--	--
OFFSET0、S0、CTC1、CTC2、STC1、STC2、KS	P1	--	P3	--	P1	P2	P3	--	P1	--	P3	--	--
OFFSET0、S0、CTC1、CTC2、STC1、STC2、KS、KSS	P1	--	--	P4	P1	P2	P3	P4	P1	--	--	--	P4

8. Calibration DLL Description

NOVOSENSE offer the calibration calculation algorithm which is DLL format. User can use the DLL to calculate the calibration coefficients according to the collected raw data and target value. The input and output parameter formats of the DLL are showed below:

8.1. Input parameters:

PData: 8-bit double-precision array, the normalized data of calibration target value

TData: 8-bit double-precision array, temperature value of sensor calibration(C)

RData: 8-bit double-precision array, the normalized data of raw data

Tstand: T0 in the step 5, reference temperature.

Pstand: P0 in the step 5, nonlinearity calibration reference pressure value.

Psize: Rdata array size.

CalMode:

Calibration Algorithm Based on NSA(C)9260X

- 2P1T mode is 1;
- 3P1T mode is 2;
- 4P1T mode is 3;
- 2P2T mode is 4;
- 3P2T mode is 5;
- 4P2T mode is 6;
- 2P3T mode is 7;
- 3P3T mode is 8;
- 4P3T mode is 9;
- 2P3T segmental calibration mode is 10;
- 3P3 segmental calibration mode is 11;
- 4P3T segmental calibration mode is 12;

8.2. Output parameters:

8-bit double-precision array, the array parameters in the order is OFFSET0, CTC1, CTC2, S0, STC1, STC2, KS and KSS.

Calibration Algorithm Based on NSA(C)9260X

9.Revision History

Revision	Description	Author	Date
1.0	Initial version	Feifei Sun	16/6/2023

Sales Contact: sales@novosns.com; Further Information: www.novosns.com

IMPORTANT NOTICE

The information given in this document (the “Document”) shall in no event be regarded as any warranty or authorization of, express or implied, including but not limited to accuracy, completeness, merchantability, fitness for a particular purpose or infringement of any third party’s intellectual property rights.

Users of this Document shall be solely responsible for the use of NOVOSENSE’s products and applications, and for the safety thereof. Users shall comply with all laws, regulations and requirements related to NOVOSENSE’s products and applications, although information or support related to any application may still be provided by NOVOSENSE.

This Document is provided on an “AS IS” basis, and is intended only for skilled developers designing with NOVOSENSE’ products. NOVOSENSE reserves the rights to make corrections, modifications, enhancements, improvements or other changes to the products and services provided without notice. NOVOSENSE authorizes users to use this Document exclusively for the development of relevant applications or systems designed to integrate NOVOSENSE’s products. No license to any intellectual property rights of NOVOSENSE is granted by implication or otherwise. Using this Document for any other purpose, or any unauthorized reproduction or display of this Document is strictly prohibited. In no event shall NOVOSENSE be liable for any claims, damages, costs, losses or liabilities arising out of or in connection with this Document or the use of this Document.

For further information on applications, products and technologies, please contact NOVOSENSE (www.novosns.com).

Suzhou NOVOSENSE Microelectronics Co., Ltd